

TB 8-11

# FOR SMALLER LOADS...



Our 8-11 tonne TB trailers are designed for general-purpose haulage and are the ideal solution for farms, horticultural and contracting businesses that require a compact, dependable workhorse for all those smaller loads.

Built for tough conditions all models are mounted on 8mm RHS chassis, which we've designed to eliminate material spillage onto the road or yard.

Protection against wear and tear is provided by heavy-gauge sides, strengthening channels and heavy-gauge floors with hollow section runners at 300mm centres which feature across the range. Long reach chromed tipping cylinders achieve approximately 50° of tip.

All TB 8-11 tonne trailers feature agricultural axles, fixed drawbar and swing door as standard.

## STANDARD FEATURES

- Hydraulic brakes
- Parking brakes
- Heavy-duty EN8 towing eye
- Skid & skid carrier
- Hydraulic hose carrier
- LED lights
- LED beacon
- Ladder
- Chromed rams
- Number plate holder
- Body prop
- Anti-chip paint on headboard
- Hydraulic hose carrier



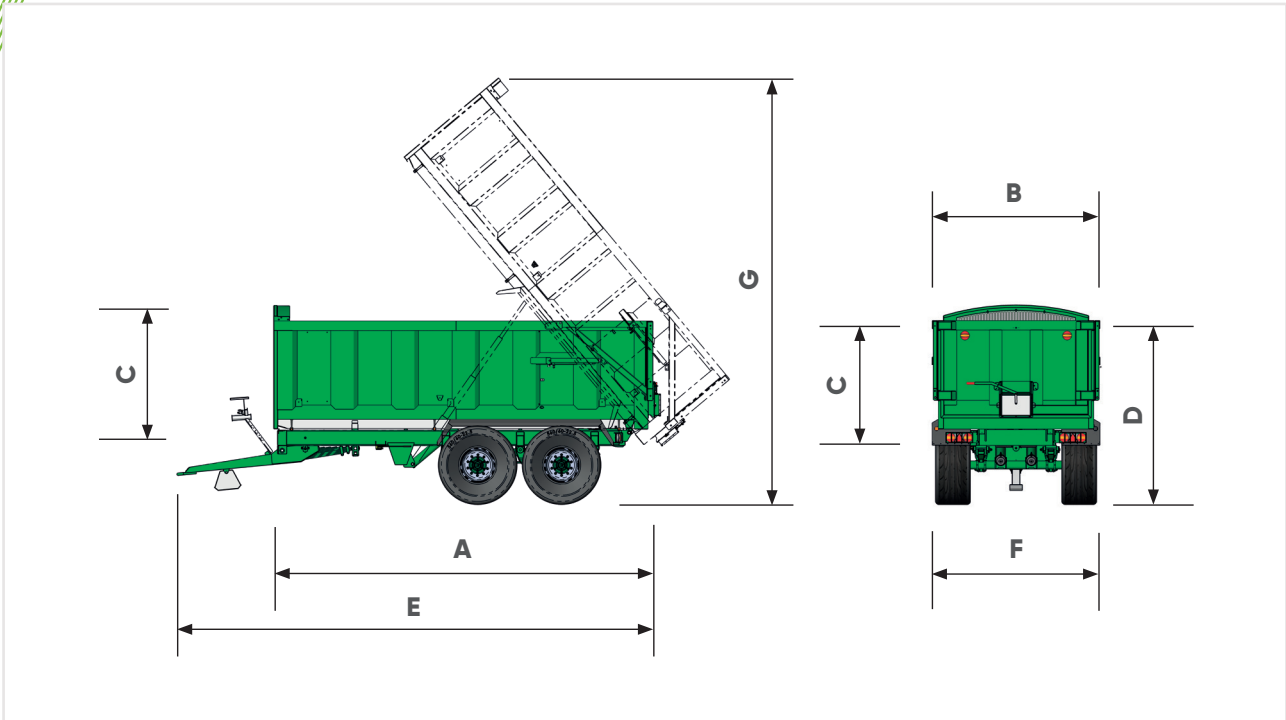

Model			TB 8	TB 9	TB 11
<b>Dimensions</b>					
Body length	A	mm	3900	4350	4800
Body width	B	mm	2350	2350	2500
Body height	C	mm	1225	1225	1225
Loading height	D	mm	2360	2360	2550
Overall length	E	mm	5540	5990	6450
Overall width	F	mm	2350	2350	2760
Tipped height	G	mm	4750	5000	5700
Body capacity		m <sup>3</sup>	10.7	11.9	13.8
<b>Misc.</b>					
Hydraulic oil	L		15.5	24.6	24.6
Number of axles			2	2	2
Axle beam	mm/studs		2x70/6	2x80/8	2x90/8
Brake size			300x60	350x90	
Brake option			H		H/A
Tyre size			12.5/80x15.3	435/50 R19.5	385/65 R22.5
Bottom chassis			200x100 RHS		250x100 RHS
Top chassis			150x75 RHS		

**BAILEY TRAILERS LIMITED**

Pride Parkway, Sleaford, Lincolnshire NG34 8GL

+44 (0) 1529 303411 sales@baileytrailers.co.uk baileytrailers.co.uk