

BEETEAPER

IF BEET IS YOUR BUSINESS...



Then you won't beat our Beeteaper trailers. This range is designed especially for transporting and heaping beet and features a unique tipping angle of approximately 60°.

We fit longer side arms and rams, which enables the rear door to open higher when compared to conventional trailers. This extra clearance permits the heaping, scraping and levelling of beet to a height of around 9'.

An RHS chassis of either 8 or 10 mm provides the strength. This clean design eliminates material spillage on road or yard. The hydraulic braking system works in tandem with your tractor, which is important when braking suddenly.

To offset the wear and tear of loading heavy materials, our trailers feature heavy-gauge sides, strengthening channels and heavy-gauge floors with hollow section runners at 300 mm centres. We fit rugged side ladders to aid stability for operators when working above the trailer height.

All Beeteaper's are fitted with 10 stud heavy-duty commercial axles on tandem springs with air brakes as standard. Additionally, a sprung drawbar featuring a leaf spring ensures the ride is smooth on all terrains whether partially or fully loaded. Mudguards fitted as standard to protect the trailer against debris and surface spray. All models feature an arched window for improved visibility when loading.

Although our Beeteaper range is designed primarily for beet, it is just as dependable when transporting grain and other crops.



STANDARD FEATURES

- ▼ Air brakes with load sensing
- ▼ Sprung drawbar
- ▼ Hydraulic rear door
- ▼ Independent hydraulic brakes
- ▼ Heavy-duty EN8 towing eye
- ▼ Parking brakes
- ▼ Tandem springs
- ▼ 3 leaf 100 mm wide 32 tonne suspension
- ▼ Mudguards & flaps
- ▼ Flotation tyres
- ▼ Arched full front window
- ▼ Extra top lights on tail door
- ▼ LED lights
- ▼ LED beacon
- ▼ Chromed rams
- ▼ Body prop
- ▼ Side ladders
- ▼ Skid & skid carrier
- ▼ Anti-chip paint on headboard
- ▼ Number plate holder
- ▼ Commercial axles



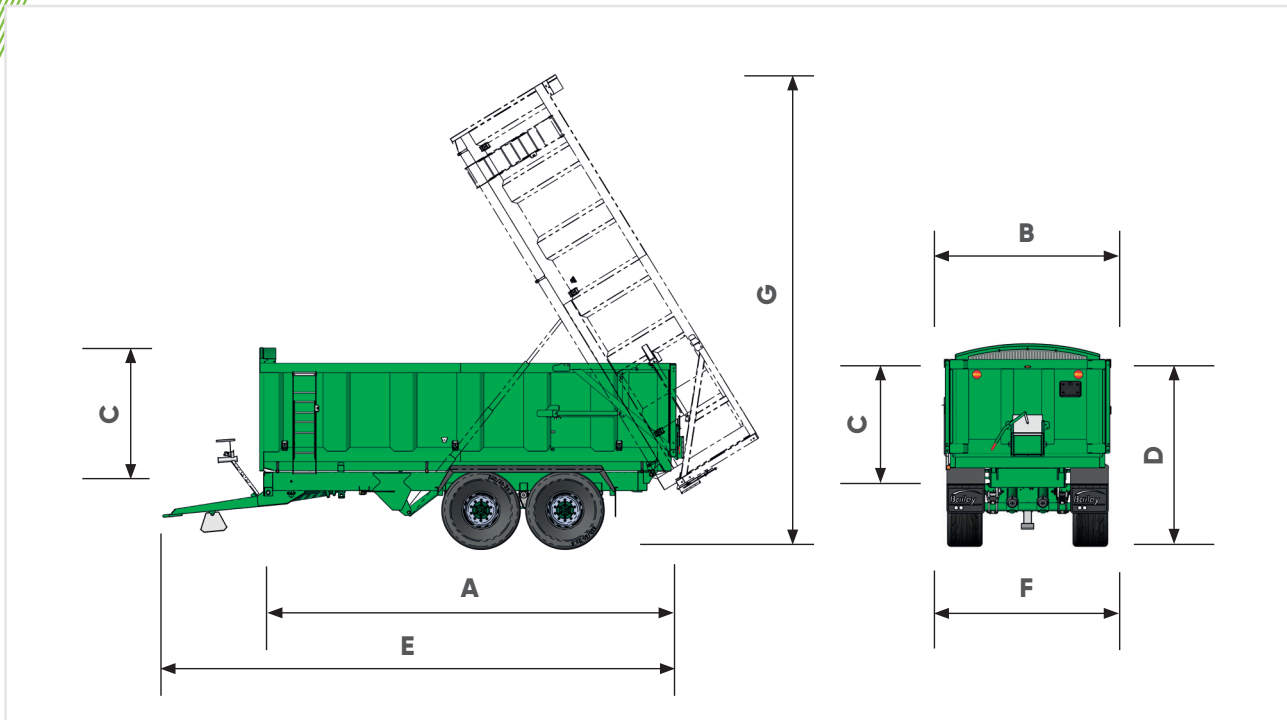

Model			BEET 16	BEET 18	BEET 20	BEET 22/3
Dimensions						
Body length	A	mm	6000	6600	7200	7800
Body width	B	mm	2500	2500	2500	2500
Body height	C	mm	1525	1525	1525	1525
Loading height	D	mm	2970	2970	2970	2970
Overall length	E	mm	7820	8430	9040	9650
Overall width	F	mm	2620	2620	2620	2620
Tipped height	G	mm	7210	7550	7980	8410
Body capacity		m³	22.0	24.1	26.3	28.5
Misc.						
Hydraulic oil	L		40.0	40.0	48.8	48.8
Number of axles			2		3	
Axle beam	mm/studs		3xcom/10			
Brake size			420x180		420x220	420x180
Brake option			H/A			
Tyre size			560/60 R22.5		650/50 R22.5	560/60 R22.5
Bottom chassis			300x150 RHS			
Top chassis			150x100 RHS			

BAILEY TRAILERS LIMITED

Pride Parkway, Sleaford, Lincolnshire NG34 8GL

+44 (0) 1529 303411 sales@baileytrailers.co.uk baileytrailers.co.uk