

AGRICULTURAL DUMPER

FOR HEAVY-DUTY WORK...



Agricultural Dumpers feature a heavy-duty RHS bottom chassis mounted on a heavy-duty tandem spring unit. This provides additional strength and durability.

An impressive tipping angle is achieved via twin extra-long reach 3 stage hydraulic cylinders.

To protect against wear and tear Agricultural Dumpers are built with 4mm sides, strengthening channels and 4mm floors with hollow section runners at 300 mm centres. Fitted on a heavy-duty tandem suspension.

STANDARD FEATURES

- Independent hydraulic brakes
- Sprung drawbars (on 12, 14 & 16)
- Heavy-duty EN8 towing eye
- Parking brakes
- Skid & skid carrier
- LED lights
- LED beacon
- Chromed rams
- Body prop
- Anti-chip paint on headboard
- Hydraulic hose carrier



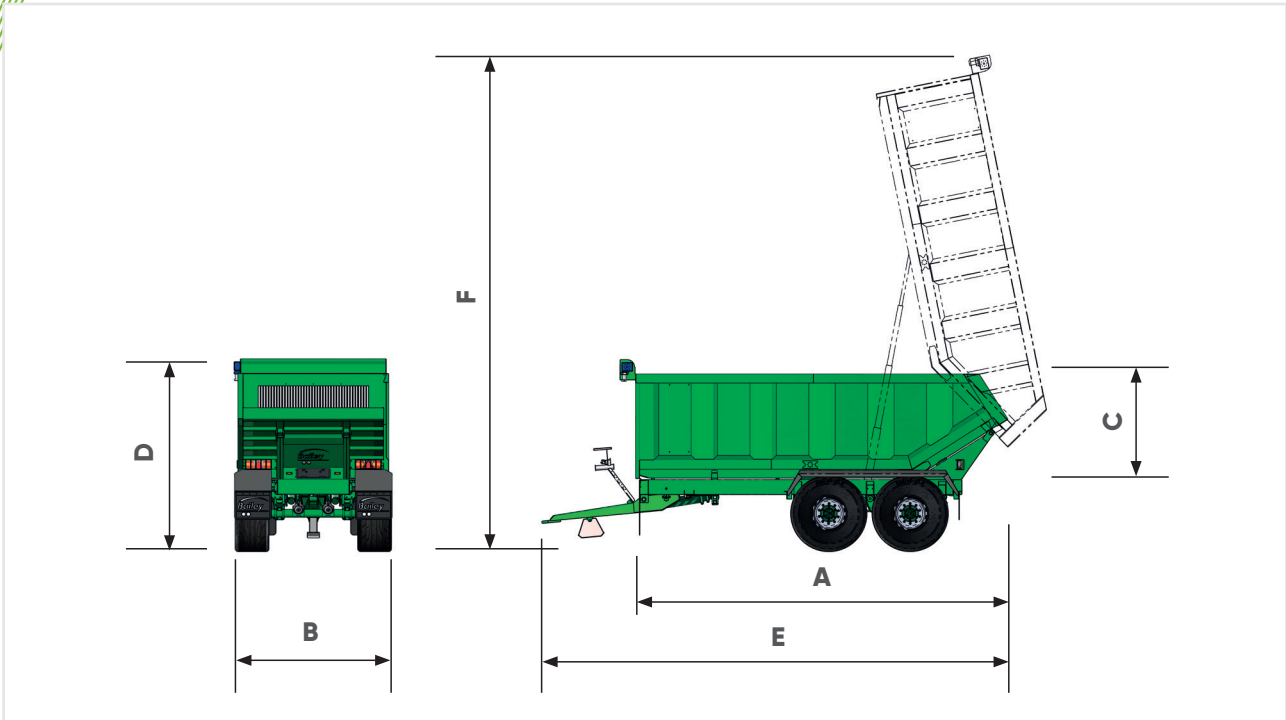

Model		DUMP 8	DUMP 10	DUMP 12	DUMP 14	DUMP 16
Dimensions						
Body length	A mm	4630	5430	6030	6030	6630
Body width	B mm	2500	2500	2500	2500	2500
Body height	C mm	1225	1225	1300	1525	1525
Loading height	D mm	2415	2570	2645	2870	2920
Overall length	E mm	6070	6750	7360	7360	8000
Tipped height	F mm	6710	7390	8000	8130	8740
Body capacity	G m³	11.50	13.80	16.50	19.50	21.70
Misc.						
Hydraulic oil	L	28.6	37.2	40.0	40.0	40.0
Number of axles		2				
Axle beam	mm/studs	2x80/8	2x90/8	2xcom/10		
Brake size		350x90	406x120		420x180	
Brake option		H		H/A		
Tyre size		435/50 R19.5		385/65 R22.5		
Bottom chassis		200x100 RHS		250x150 RHS		300x150 RHS
Top chassis		150x75 RHS		150x100 RHS		

BAILEY TRAILERS LIMITED

Pride Parkway, Sleaford, Lincolnshire NG34 8GL

+44 (0) 1529 303411 sales@baileytrailers.co.uk baileytrailers.co.uk