

# EJECTOR



## WHEN YOU WANT TO MOVE MORE . . .

**Ejector trailers offer a safe and efficient solution to farmers and contractors who are looking to increase transportable volumes.**

Our Ejector trailer is unique. By fitting larger rams we've increased the height clearance between the tail door and the trailer, which allows heaped loads to be ejected more easily.

We build our Ejector trailers as fully welded constructions. A rectangular hollow section chassis provides optimum strength with heavy-gauge sides, strengthening channels and heavy-gauge floors.

A 32 tonne suspension permits high hauling speeds in tough conditions, whilst stability is provided by the multi-leaf drawbar spring, which cushions the ride across all terrains.

### **Standard features**

Hydraulic and air brakes, LED lights, sprung drawbar, hydraulic door, full front window, LED beacon, skid & skid carrier, mudguards and flaps, extra top lights on tail door, 560/60 R22.5 BKT wheel assemblies.



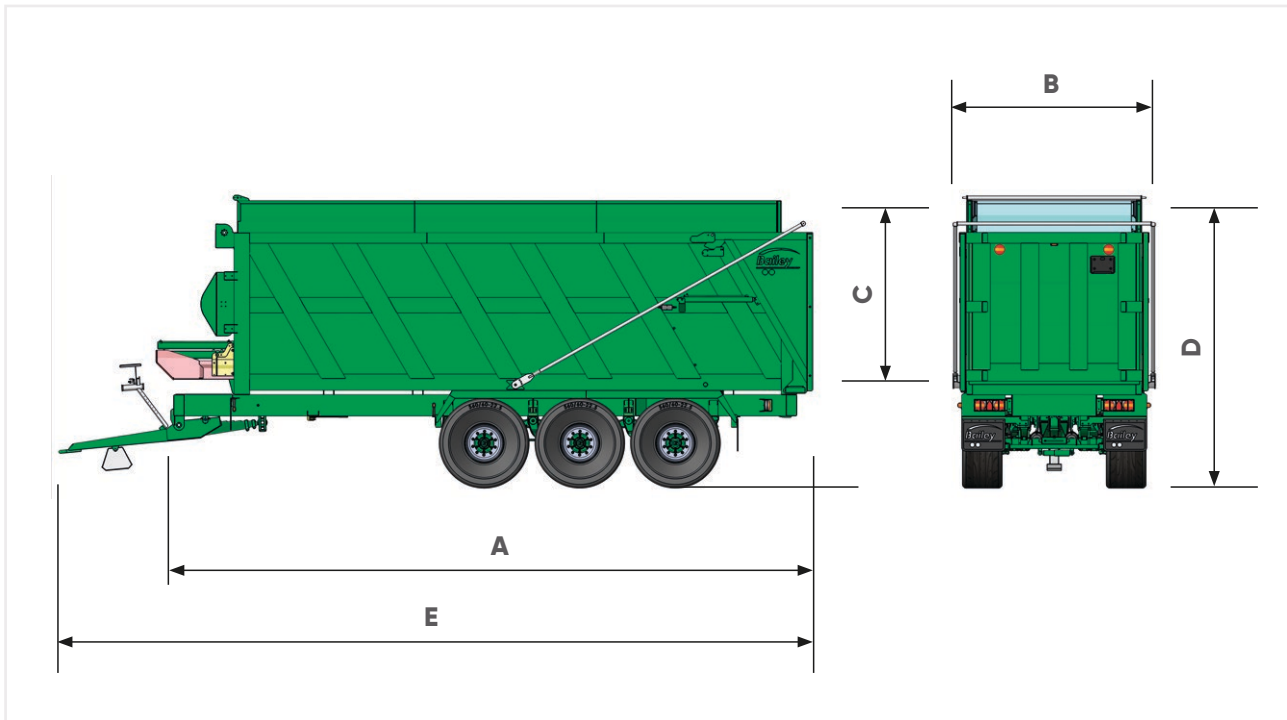

Model		EJECTOR 18	EJECTOR 22 TRI
<b>Dimensions</b>			
Body length	A mm	6700	8000
Body width	B mm	2500	2500
Body height	C mm	2100	2100
Loading height	D mm	3500	3500
Overall length	E mm	8500	9800
Body capacity	m <sup>3</sup>	34	40
Hydraulic oil	L	30	35
Number of axles		2	3
Axle beam	mm/studs	com/10	com/10
Brake size		420x180	420x180
Brake option		H/A	H/A
Suspension		3 leaf 32 T	3 leaf 48 T
Sprung d/bar		STD	STD
Tyre size		385/65 R22.5	385/65 R22.5
Bottom chassis		250x150 RHS	250x150 RHS

## BAILEY TRAILERS LIMITED

Pride Parkway, Sleaford, Lincolnshire NG34 8GL

+44 (0) 1529 303411 [sales@baileytrailers.co.uk](mailto:sales@baileytrailers.co.uk) [baileytrailers.co.uk](http://baileytrailers.co.uk)